

Electromagnetically actuated shotbolt lock unit

1

Product group

G SC X

Funktion

- Pull type (de-energized locked) or push type (de-energized unlocked)
- Installed return spring
- Almost linear magnetic force vs. stroke characteristic

Construction

- Central fastening
- Maintenance free bearings with high service life
- Armature space protected by o-ring
- Robustly built stainless locking bolt
- Insulation materials of the excitation winding correspond to thermal class F
- Electrical connection via connector plug type Z KB in compliance with DIN EN 175301-803
- Protection class according to DIN VDE/DIN EN 60529, when properly installed
 - Electrical connection and coil
 - Receptacles according to DIN 46247 IP 00
 - Plug connection via connector plug: IP54
 - Tube: IP54

Application examples

- Blocking, limiting, interlocking of mechanical devices of all kind

Options

- Further electrical connections on request
- Please contact us for application related solutions

Standards

- Design and testing according to DIN VDE 0580
- Quality management to ISO 9001



Fig. 1: Type G SC X 037 M43 A02

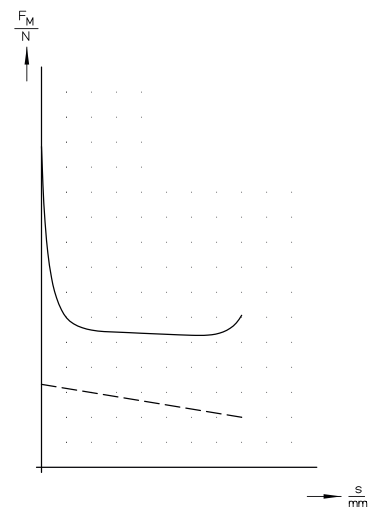

Fig. 2: Force vs. stroke characteristic

Technical data

G SC X	037 M 43 A02 (pull-type)	037 N 43 A02 (push-type)	045 M 43 A01 (pull-type)	045 N 43 A01 (push-type)	063 M 43 A01 (pull-type)
Rated voltage U_N	24 V				
Operating mode	S1 (100 %)				
Reference temperature ϑ_{13}	35 °C				
Rated power P_{20}	19,1 W		18,6 W		36 W
Stroke	8 mm		10 mm		12 mm
Magnetic force F_M	10,8 N	9,8 N	11 N	10 N	21,5 N
Admissible lateral force in normal position	600 N		900 N		2000 N

Notes on the tables

The force values indicated in the tables refer to 90 % of the rated voltage, ($U_N = 24$ V, for other voltages deviations of magnetic force may occur) and in the normal operating temperature.

Due to natural dispersion the force values and the force values of the spring may deviate by ± 10 % from the values indicated in the tables.

The normal operating temperature is based on:

- Mounting on badly conductive base
- Rated voltage $U_N = 24$ V
- Operating mode S1 (100%)
- Reference temperature 35° C

The stroke movement effected by the electromagnetic force can be pulling or pushing depending on the design.

The reset in the stroke start position is effected by the built-in spring. Both operations „de-energized locked“ and „de-energized unlocked“ are possible. However, the operation „de-energized locked“ is preferable.

The central fastening guarantees a reliable and flexible assembly. Further sizes and designs with signal switch or manual override on request.

Rated voltage

Rated voltage is $U_N = 24$ V. An adaptation of the exciter coil to a rated voltage less than $U_N = 120$ V is possible on request.

The devices correspond to protection class III. Electrical equipment of protection class III may be only connected to low voltage systems (PELV, SELV)(IEC 60364-4-41). The design limit of the equipment is a rated voltage not higher than 120 V (EN 61140:2002) with DC. On request we are pleased to check to what extent the delivery of higher rated voltages is possible as special solutions by agreement.

Information and remarks concerning European directives can be taken from the correspondent information sheet which is available under Produktinfo.Magnet-Schultz.com.

Note on the RoHS Directive

According to our current state of knowledge the devices pictured in this document do not contain any substances in concentration values or applications for which putting into circulation with products manufactured from them is prohibited in accordance to RoHS.

Please make sure that the described devices are suitable for your application. Our offers for these devices are based on the assumption of maximal 8 in an FMEA severity table, i. e. in case of malfunction of the device model as offered, there is, amongst others, no jeopardy of life or limb. Supplementary information concerning its proper installation can be taken also from the  –Technical Explanation, the effective DIN VDE0580 as well as the relevant specifications.

This part list is a document for technically qualified personnel.

The present publication is for informational purposes only and shall not be construed as mandatory illustration of the products unless otherwise confirmed expressively.

Dimensional drawing



Bild 3: Type G SC X 037 M 43 A02
Pull type (de-energized locked)



0 mm ≈ 35 N

Fig. 4: Force vs. stroke characteristic and return spring for G SC X 037 M43 A02

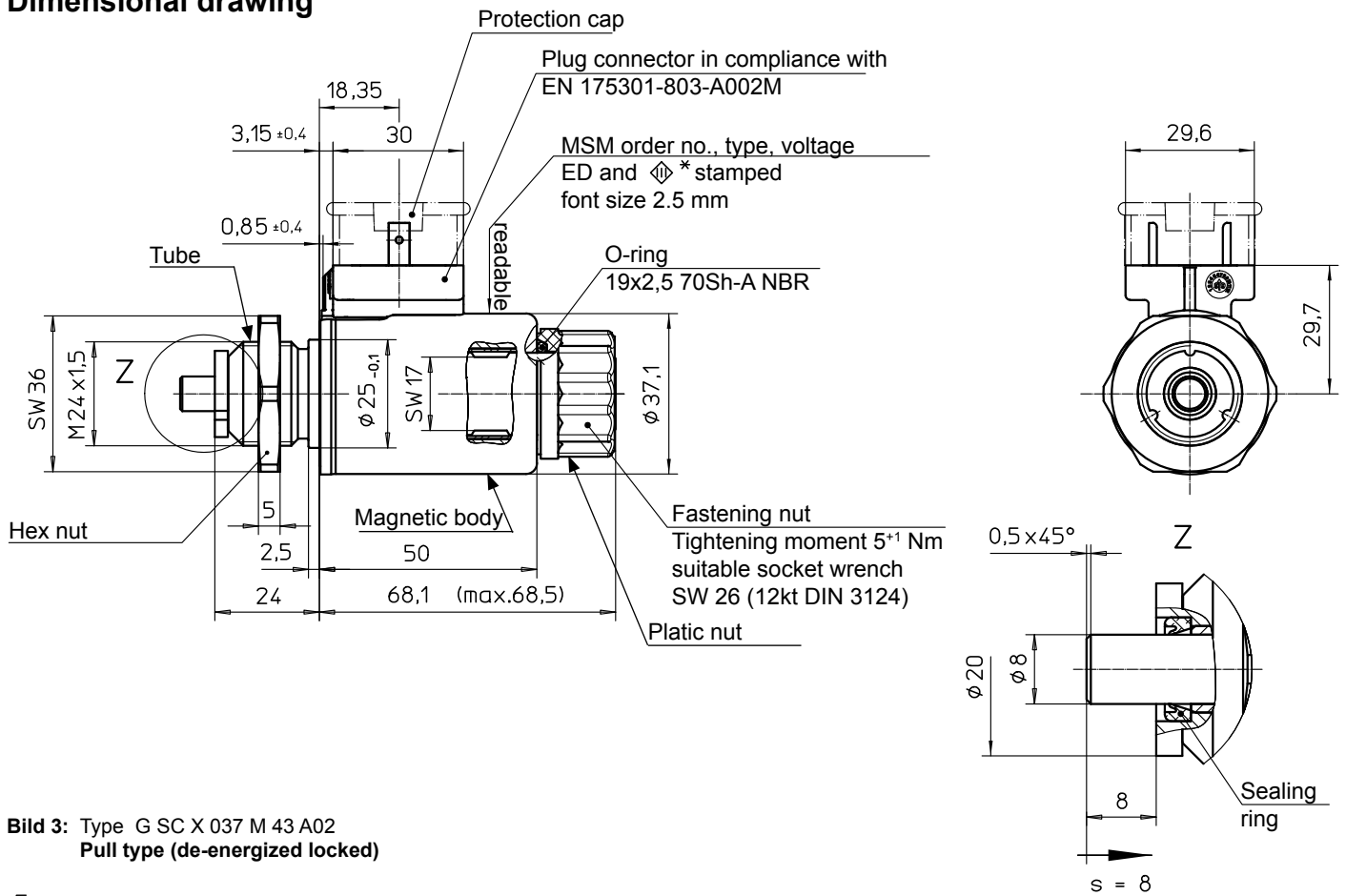
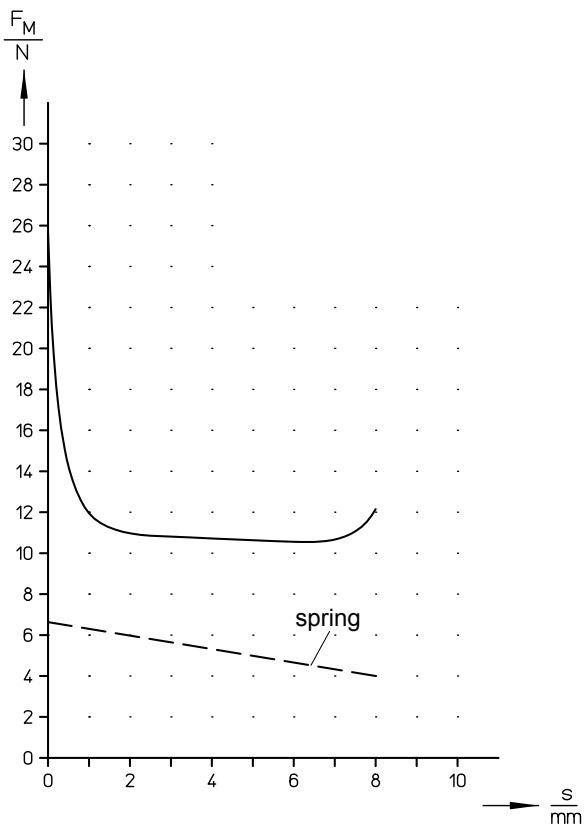
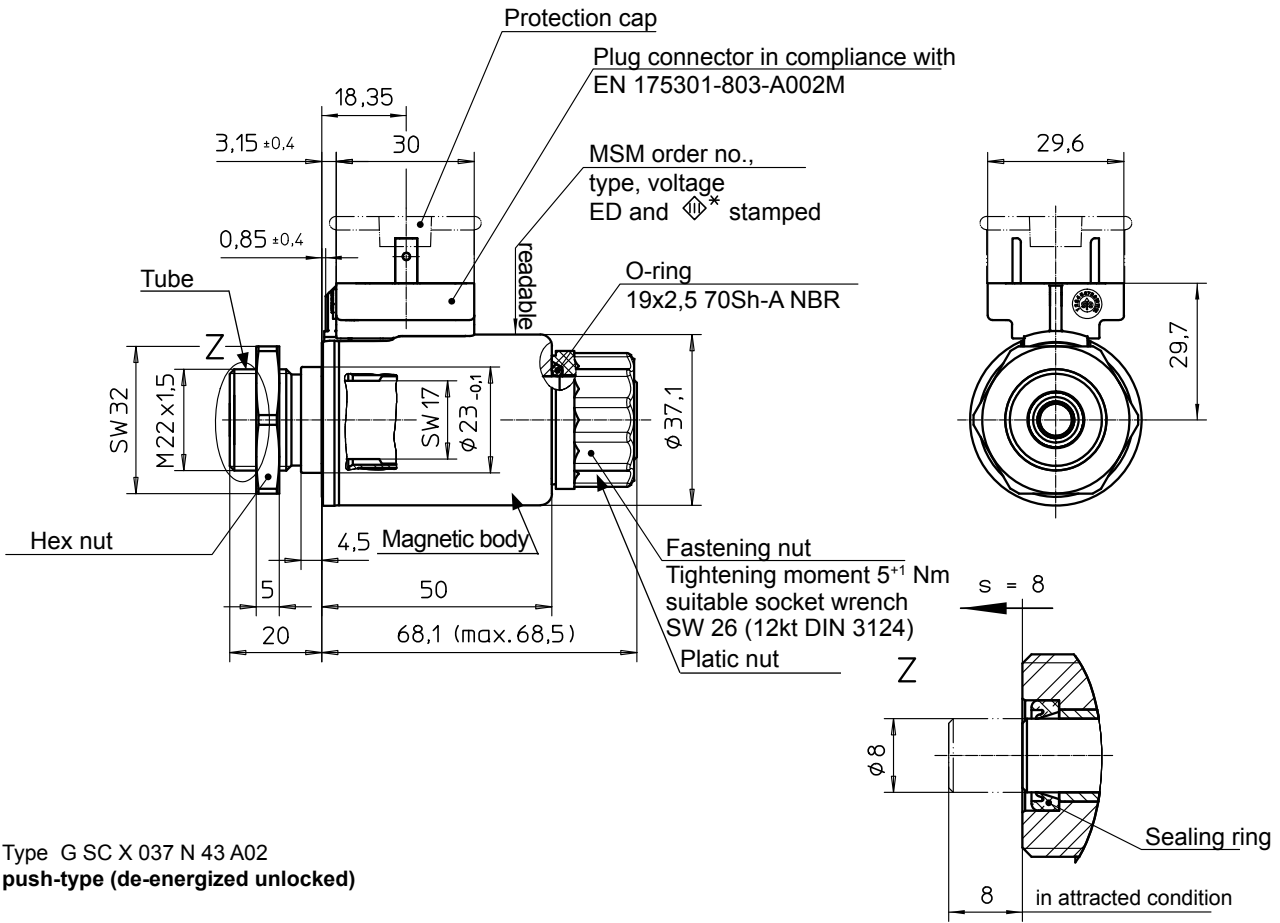

Fig. 5: Type G SC X 037 N 43 A02
push-type (de-energized unlocked)

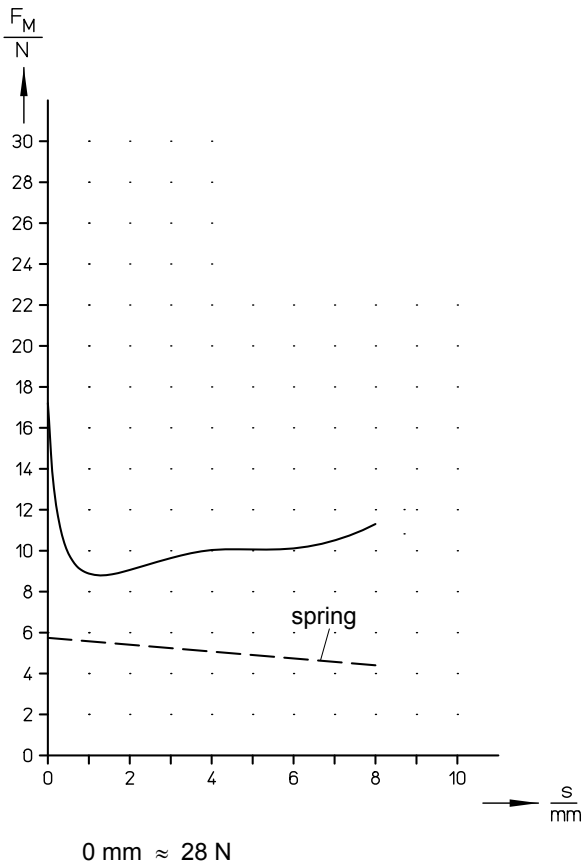
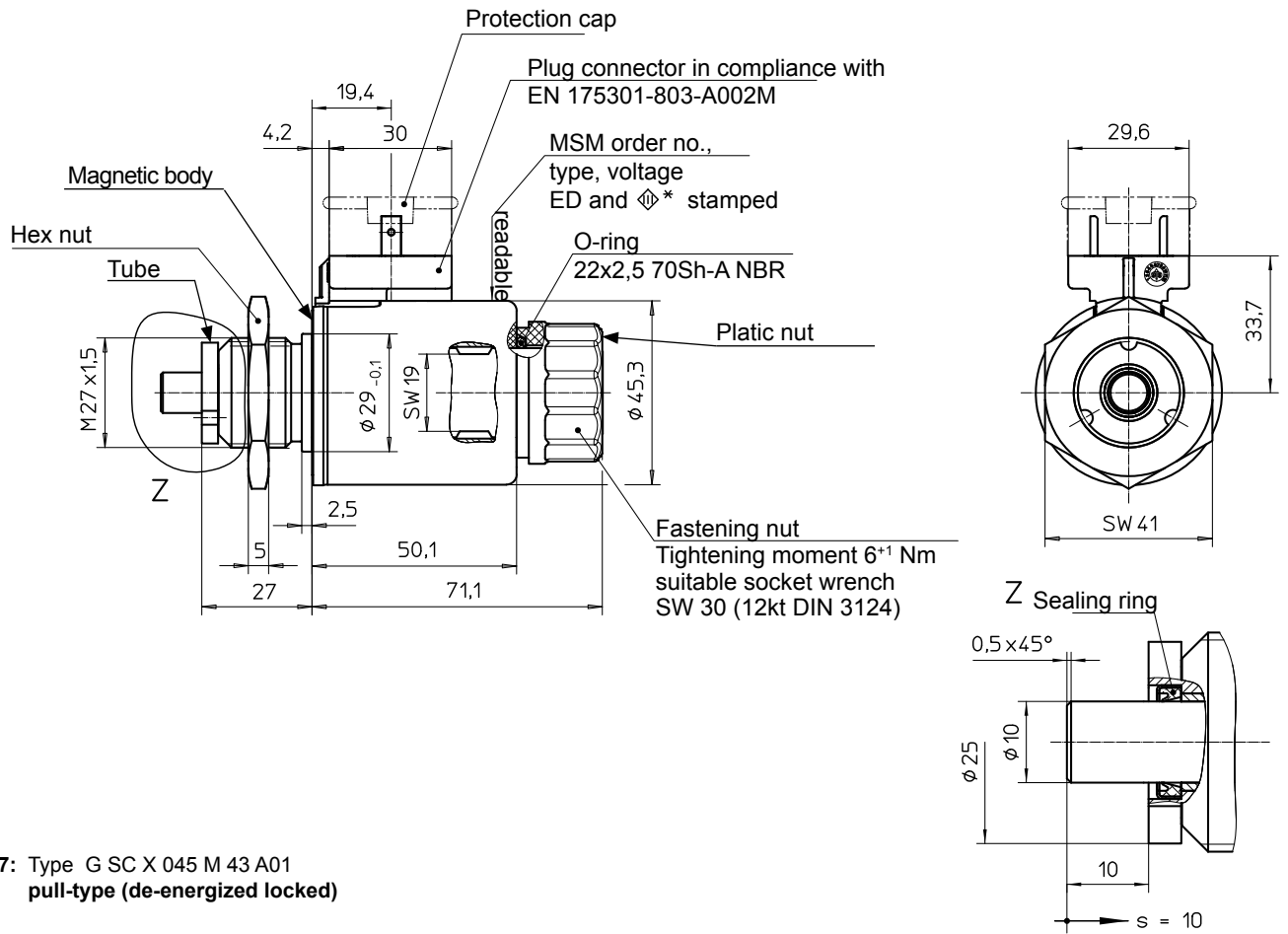
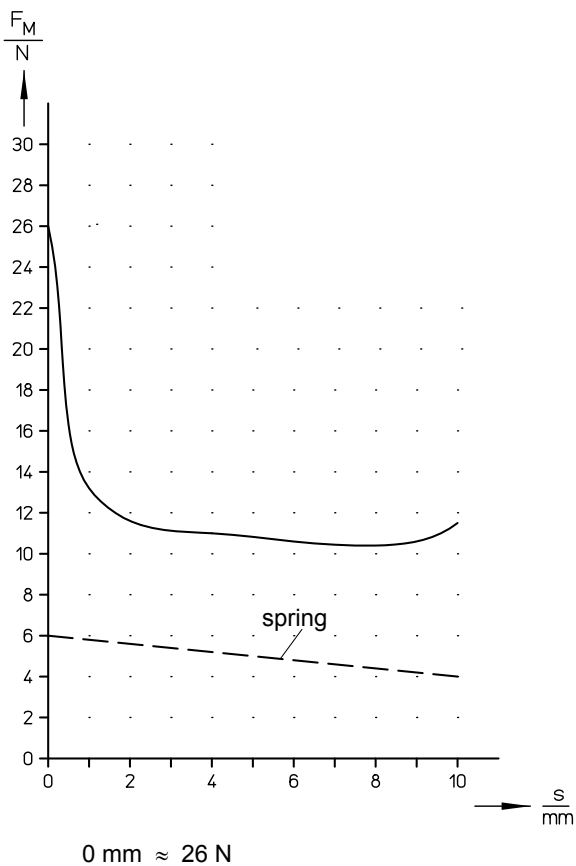

Fig. 6: Force vs. stroke characteristic and return spring
for G SC X 037 N43 A02



**Fig. 7: Type G SC X 045 M 43 A01
pull-type (de-energized locked)**



0 mm ≈ 26 N

**Fig. 8: Force vs. stroke characteristic and return spring
for G SC X 045 M43 A01**

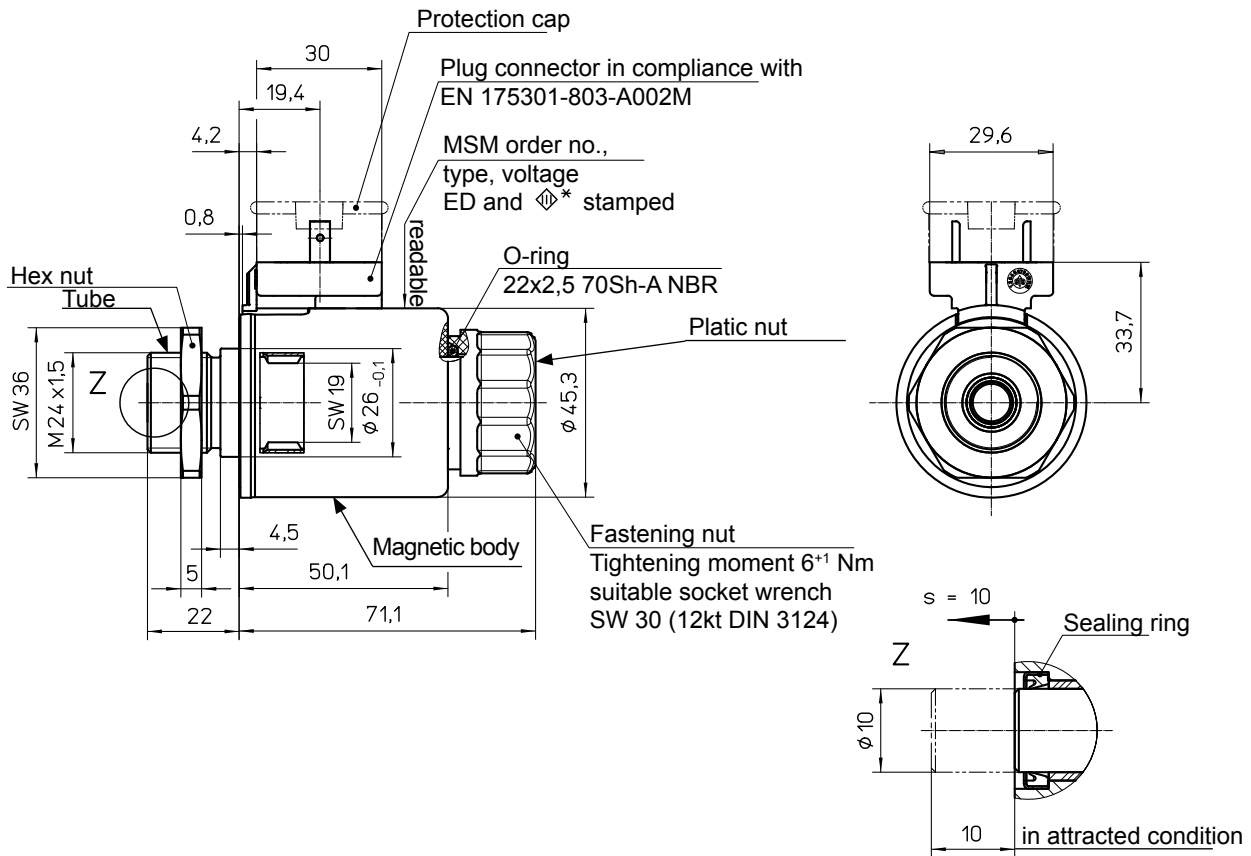
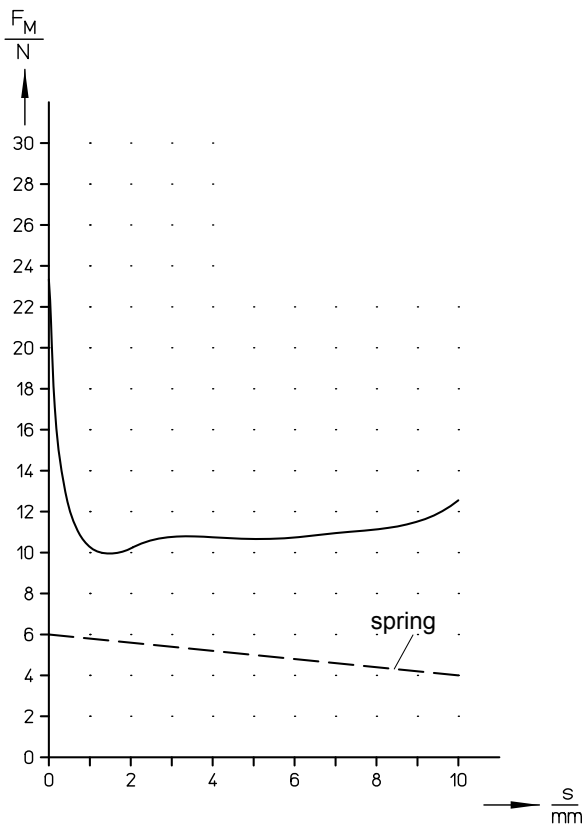

Fig. 9: Type G SC X 045 N 43 A01
push-type (de-energized unlocked)



0 mm ≈ 24 N

Fig. 10: Force vs. stroke characteristic and return spring
for G SC X 045 N43 A01

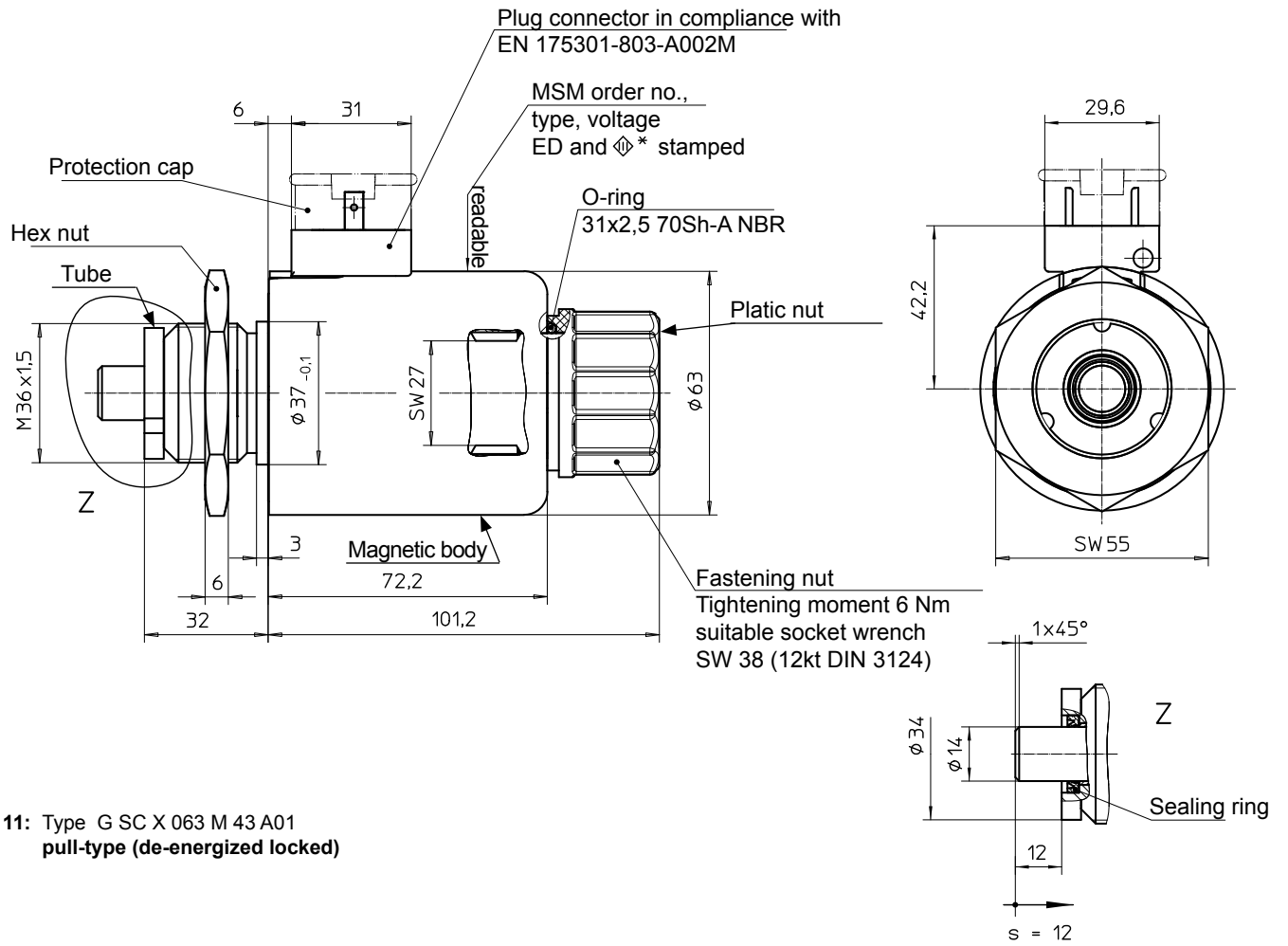

Fig. 11: Type G SC X 063 M 43 A01
pull-type (de-energized locked)

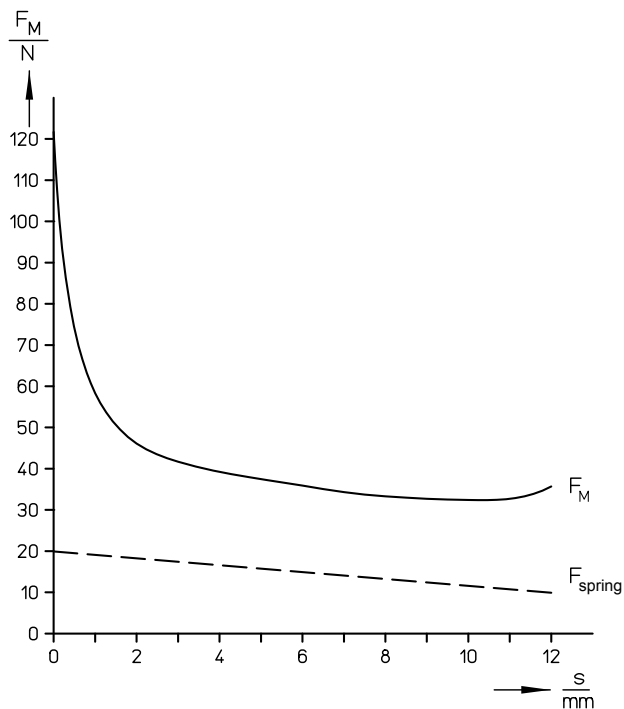



Fig. 12: Force vs. stroke characteristic and return spring
for G SC X 063 M43 A01

Type code

Designation	Working method	Size (ø)
G SC X 037 M43 A02	pull-type (de-energized locked)	37 mm
G SC X 037 N43 A02	push-type (de-energized unlocked)	
G SC X 045 M43 A01	pull-type (de-energized locked)	45 mm
G SC X 045 N43 A01	push-type (de-energized unlocked)	
G SC X 063 M43 A01	pull-type (de-energized locked)	63 mm

Order example

Type G SC X 037 M43 A02
 Voltage  24 V DC
 Operating mode S1 (100 %)

Specials designs

Please do not hesitate to ask us for application-oriented problem solutions. In order to find rapidly a reliable solution we need complete details about your application conditions. The details should be specified as precisely as possible in accordance with the relevant  -Technical Explanations.

If necessary, please request the support of our corresponding technical office.