

## On/Off - Solenoids for Hydraulics

# 4

Product group

### G HP Y 037, 045, 063

- According to DIN VDE 0580
- Armature space pressure tight  
Nominal operating pressure (dynamic)
- Increasing force vs. stroke characteristic
- Quick response times
- Push type
- Mounting via central thread
- Simple exchange of the solenoid body without opening the hydraulic circuit
- Insulation materials of the excitation winding correspond to thermal class F  
(H available on request)
- Electrical connection and protection class when properly installed:
  - Plug connection by spade connectors according to DIN 46 247  
Protection class according to DIN VDE 0470/  
EN 60 529 – IP00
  - Plug connection via plug connector according to DIN EN 175 301-803  
Screwed cable glands (4 x 90° positions)  
Protection class according to DIN VDE 0470/  
DIN EN 60529 – IP 65
- Manual override
- Please contact us for application related solutions
- Application examples:  
Actuation of hydraulic and special valves



Fig. 1: Type G HP Y 037 N54 A01

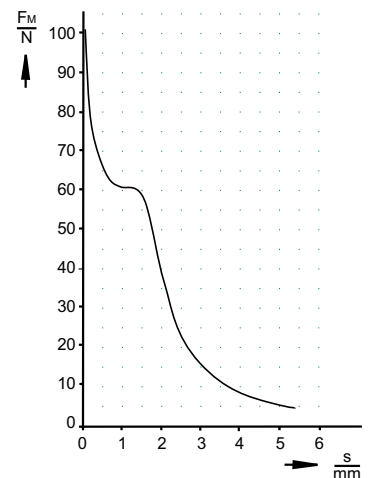

Fig. 2: Magnetic force v stroke graph

## Technical data

<b>G HP Y ... N54 A01</b>		<b>037</b>	<b>045</b>	<b>063</b>
Operating mode		S1 (100 %)	S1 (100 %)	S1 (100 %)
Reference temperature $\vartheta_{11}$	(°C)	50	50	50
Rated Voltage U	(V)	24	24	24
Overall stroke s	(mm)	<b>Magnetic force <math>F_M</math> (N)</b>		
	0	100	140	270
	0,5	65	105	215
	1	60	86	180
	1,5	57	79	160
	2	40	55	145
	3	15	22	128
	3,5	11	15	125
	4	8	11	100
	5	5	5	58
	6			37
	7			25
8			19	
9			14	
Working stroke $s_w$	(mm)	1,5	1,5	3,5
Nominal operating pressure (dynamic)	(bar)	250	210	210
Work rating $W_N$ at working stroke $s_w$	(Ncm)	8,5	11,9	43,8
Rated power $P_{20}$	(W)	25,4	29,1	47,2
Frequency of operation	(1/h)	3.600	3.600	3.600
Armature weight $m_A$	(kg)	0,04	0,05	0,16
Solenoid weight $m_M$	(kg)	0,41	0,57	1,57
The heat-rise test is based on mounting on a hydraulic valve with base plate with the following minimum dimensions	hydraulic valve (mm)	46 x 46 x 66	46 x 46 x 66	67 x 67 x 82
	base plate (mm)	66 x 46 x 30	66 x 46 x 30	102 x 115 x 30

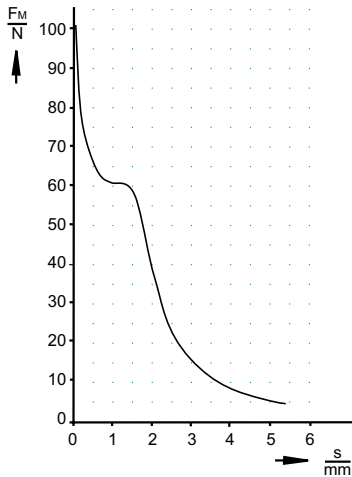

Fig. 2: Magnetic force v stroke graph size 037

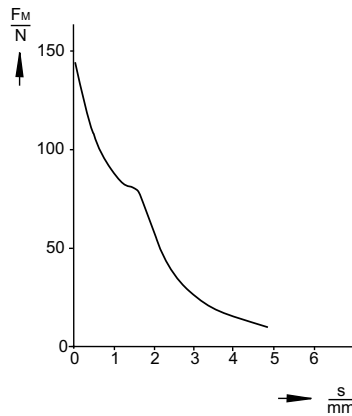

Fig. 3: Magnetic force v stroke graph size 045

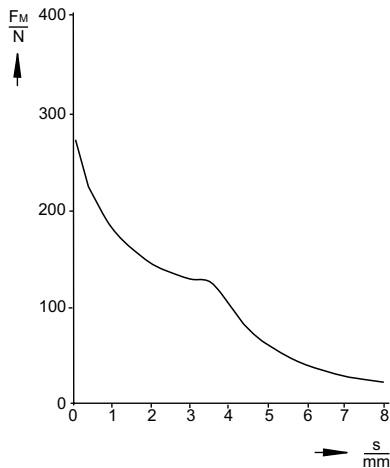

Fig. 4: Magnetic force v stroke graph size 063

For deviations from the indicated operating conditions regarding reference temperature, operating mode, rated voltage and dimensions of hydraulic slide and base plate, adaptations of the exciter coil might be necessary which result in modifications of the magnetic force.

The indicated technical data refer to an A.C. power supply with bridge rectifier. The coil winding can be adjusted to other current and resistance values on request.

Owing to natural dispersion magnetic-force values may deviate by  $\pm 5\%$  from the listed values.

On request, armature space can be deaerated and pushrod can be adjusted.

Solenoid interior and armature bearing are resistant to all neutral fluids that are commonly used in hydraulics.

Please contact us if you intend to use other operating media.

**Information and remarks concerning European directives** can be taken from the correspondent information sheet which is available under [Produktinfo.Magnet-Schultz.com](http://Produktinfo.Magnet-Schultz.com).

**Note on the RoHS Directive**

According to our current state of knowledge the devices pictured in this document do not contain any substances in concentration values or applications for which putting into circulation with products manufactured from them is prohibited in accordance to RoHS.

**Please make sure that the described devices are suitable for your application. Our offers for these devices are based on the assumption of maximal 8 in an FMEA severity table, i. e. in case of malfunction of the device model as offered, there is, amongst others, no jeopardy of life or limb. Supplementary information concerning its proper installation can be taken also from the  -Technical Explanation, the effective DIN VDE0580 as well as the relevant specifications.**

This part list is a document for technically qualified personnel.

The present publication is for informational purposes only and shall not be construed as mandatory illustration of the products unless otherwise confirmed expressively.

The devices with DIN connector comply with protection class 1.

Please note that for the proper electrical installation, a protective conductor connection at tube resp. valve has to be ensured.

## Dimensional drawing and Connection geometry

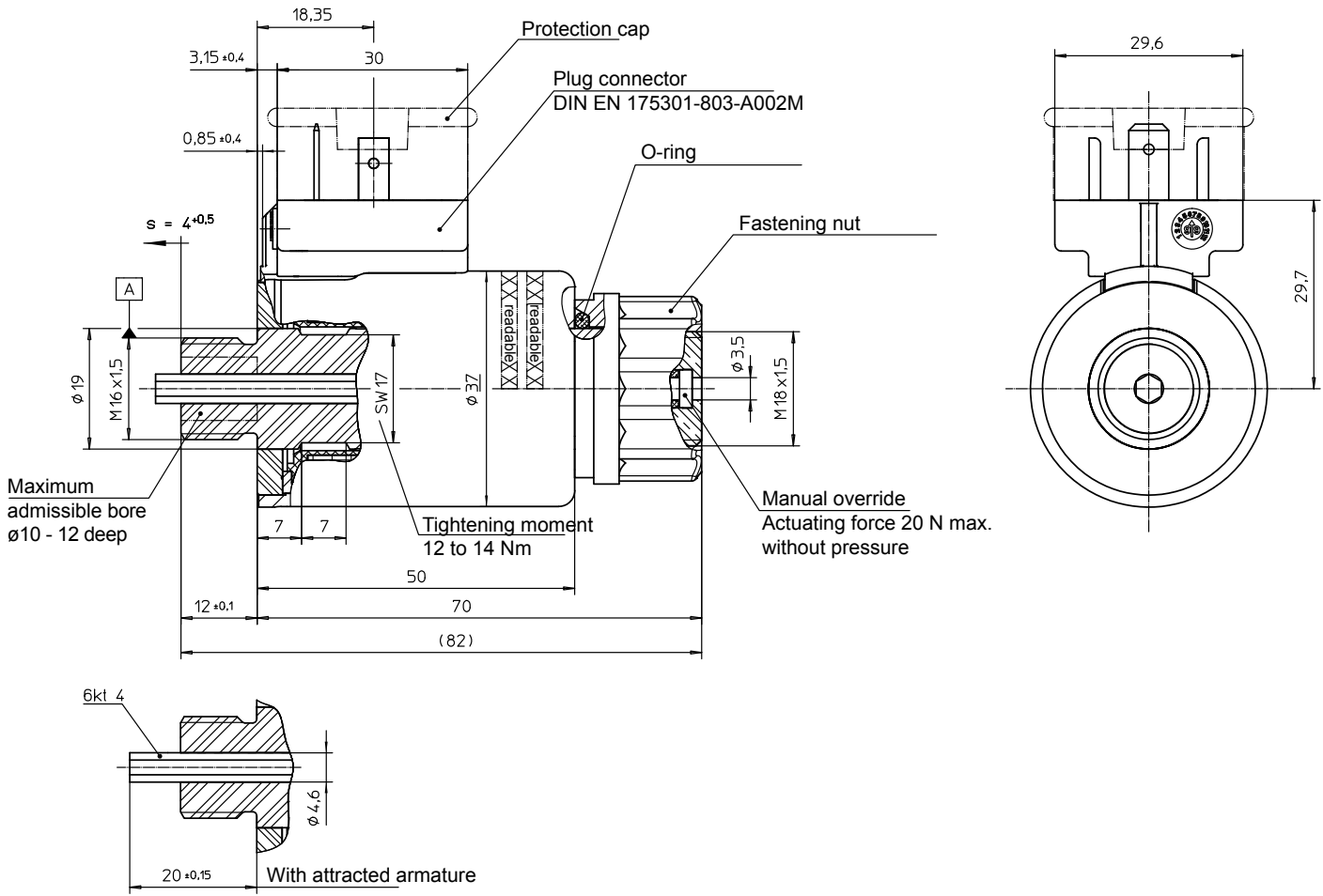

Fig. 6: Dimensional drawing to Type G HP Y 037 N54 A01

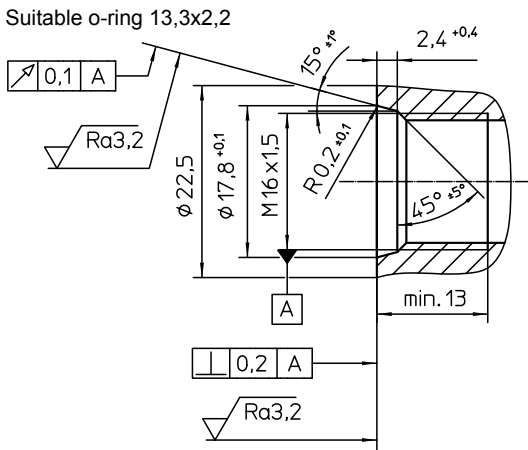

Fig. 7: Connection geometry to Type G HP Y 037 N54 A01

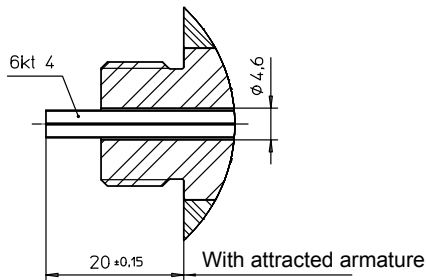
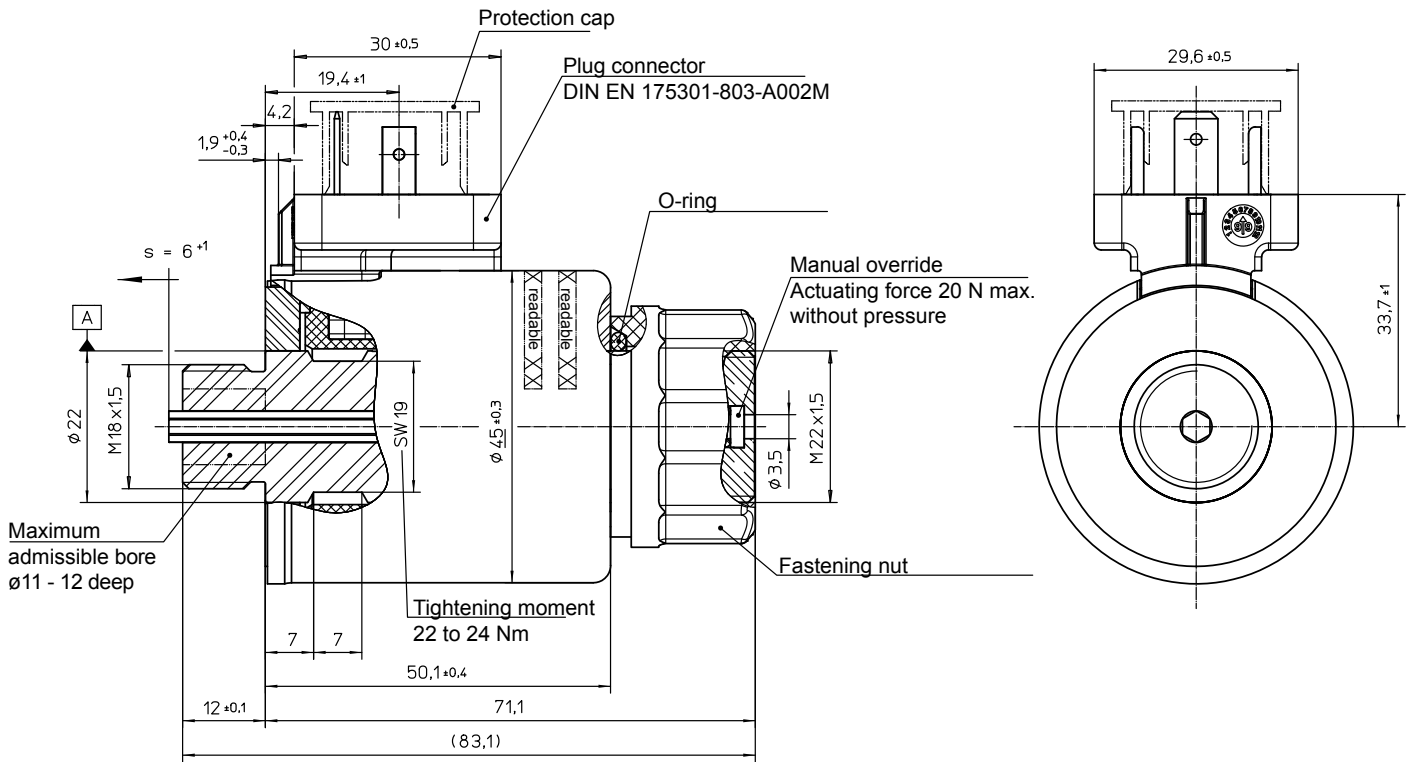

Fig. 8: Dimensional drawing to Type G HP Y 045 N54 A01

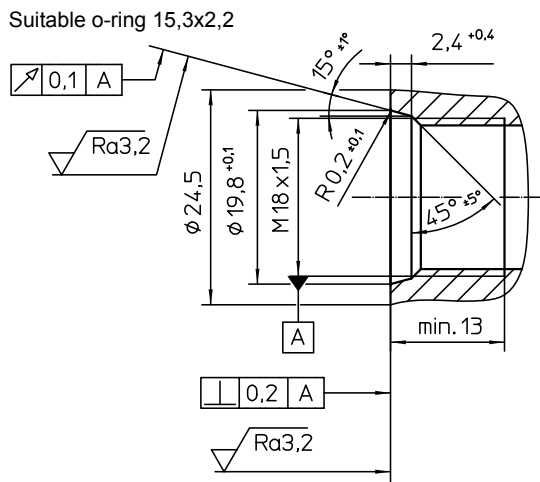

Fig. 9: Connection geometry to Type G HP Y 045 N54 A01

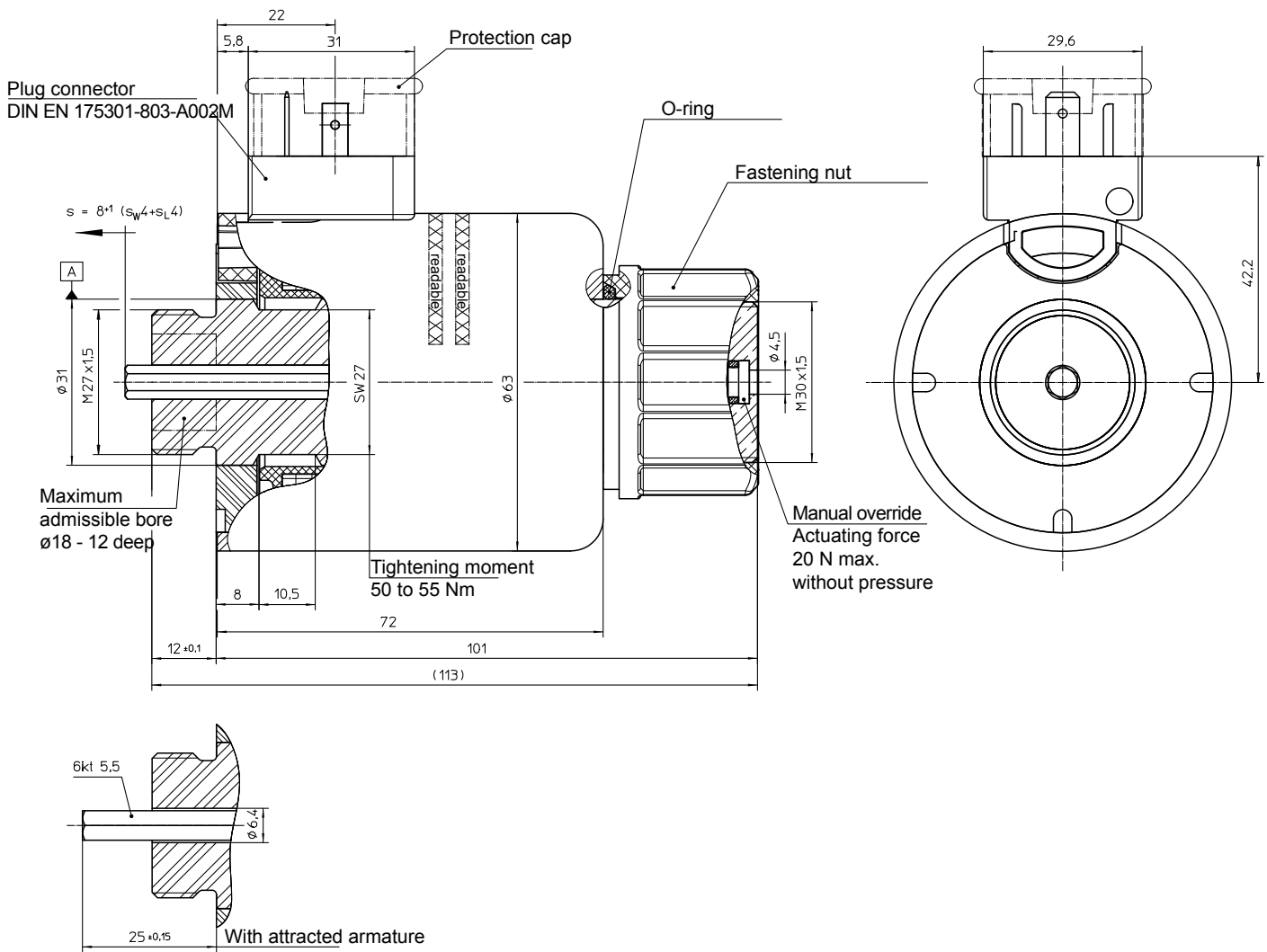

Fig. 10: Dimensional drawing to Type G HP Y 063 N54 A01

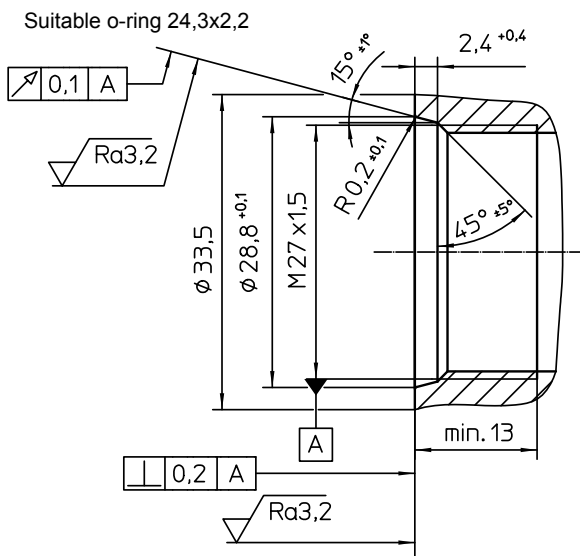
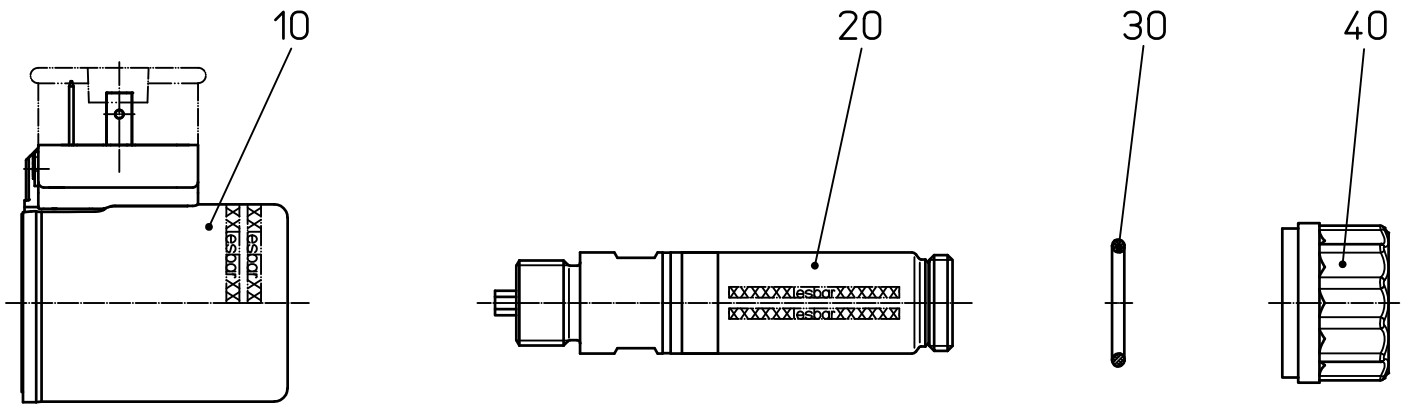

Fig. 11: Connection geometry to Type G HP Y 063 N54 A01

**Single components – delivery only as complete device, single parts on request**



Baugröße	Pos.	Benennung	Sach-Nr.	
<b>037</b>	10	Magnetic body	FHMG037925428	
	20	Tube	FHTS037926099	
	30	O-ring	781754	19 x 2,5 NBR 70 Shore A
	40	Fastening nut	472793	suitable socket wrench SW26 (12 kt DIN 3124) tightening torque 5 <sup>+1</sup> Nm
<b>045</b>	10	Magnetic body	FHMG045926433	
	20	Tube	FHTS045923690	
	30	O-ring	781744	22 x 2,5 NBR 70 Shore A
	40	Fastening nut	472778	suitable socket wrench SW30 (12 kt DIN 3124) tightening torque 6 <sup>+1</sup> Nm
<b>063</b>	10	Magnetic body	FHMG063924585	
	20	Tube	FHTS063923685	
	30	O-ring	781755	31 x 2,5 NBR 70 Shore A
	40	Fastening nut	472794	suitable socket wrench SW38 (12 kt DIN 3124) tightening torque 6 <sup>+1</sup> Nm

**Further variations for the electrical connection on request  
and explosion-proof executions according to ATEX**

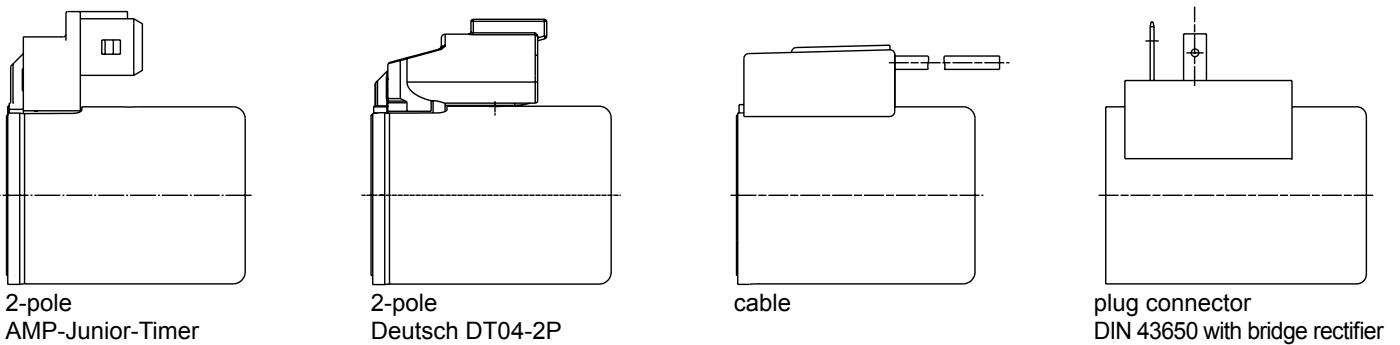

**Connection variations for tube centre thread**

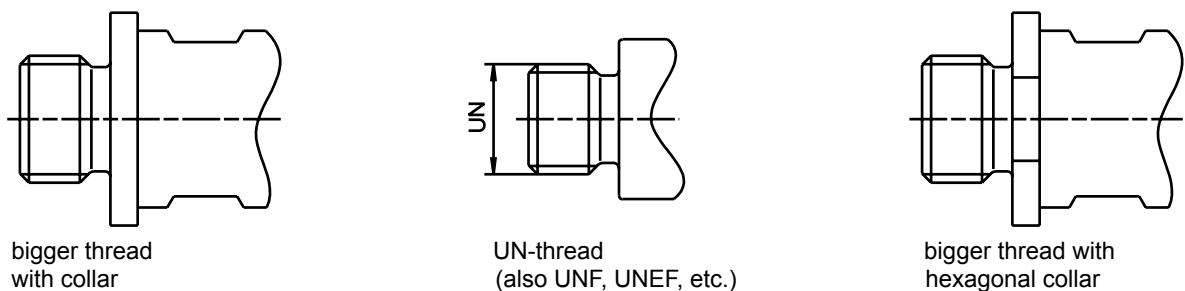

## Type code

Type	Size = $\varnothing$	Data
G HP Y 037 N54 A01	37 mm	See table page 2
G HP Y 045 N54 A01	45 mm	
G HP Y 063 N54 A01	63 mm	

## Example

Type                    G HP Y 037 N54 A01  
 Voltage                 $\equiv$  24 V DC  
 Operating mode       S1 (100 %)

## Specials designs

Please do not hesitate to ask us for application-oriented problem solutions. In order to find rapidly a reliable solution we need complete details about your application conditions. The details should be specified as precisely as possible in accordance with the relevant -Technical Explanations.

If necessary, please request the support of our corresponding technical office.