

DC single-acting high performance solenoids

1

Product group

F HM G + F MT X

Replacement for G MC X

Function

- Push and pull type
- Increasing force vs. stroke characteristic

Construction

- Central fastening
- Maintenance free bearings with high service life
- Insulation materials of the excitation winding correspond to thermal class F
- Electrical connection via connector plug type Z KB according to DIN EN 175301-803
- Protection class according to DIN VDE/DIN EN 60529, when properly installed
 - Electrical connection and solenoid body
 - Receptacles according to DIN 46247 IP 00
 - Plug connection via connector plug IP65
- Tube: IP20

Application examples

- Tooling machines, office machines, packing machines, textile machines
- Measuring and control technology

Options

- Further electrical connections see data sheet F HM G and on request
- Please contact us for application related solutions
- ATEX-version see data sheet F MME + F MT X

Standards

- Design and testing according to DIN VDE 0580
- Quality management to ISO 9001



Fig. 1 Solenoid consisting of magnetic body type F HM G and tube type F MT X

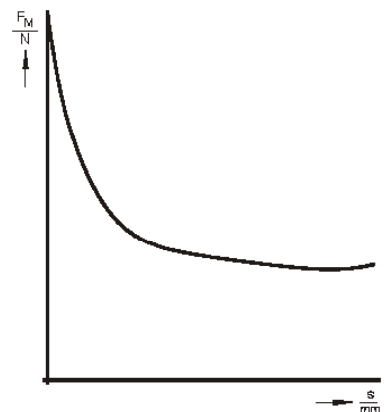

Fig. 2: force vs. stroke characteristic

Technical data

Size	037					045					063				
Rated voltage U_N (VDC)	24					24					24				
Reference temperature ϑ_{13} (C°)	35					35					35				
Operating mode	S1	S3	S3	S3	S3	S1	S3	S3	S3	S3	S1	S3	S3	S3	S3
rel. duty cycle	100%	40%	25%	15%	5%	100%	40%	25%	15%	5%	100%	40%	25%	15%	5%
Stroke s (mm)	Magnetic force (N)					Magnetic force (N)					Magnetic force (N)				
0	29,5	43,5	49	62	80	43	61	73	86	124	142	192	on request		
1	14	24	28	37	49	18	31	40	49	77	74	115			
2	13	22	26	35	46	15	26	34	43	69	56	90			
3	12	21	25	35	46	14	23	31	40	65	49	80			
4	11	20	25	35	47	12	21	28	37	63	45	74			
5	11	19	24	34	49	11	19	26	35	62	42	69			
6	11	19	23	33	50	11	18	25	33	61	41	66			
7	11	18	22	32	49	11	18	24	32	60	39	63			
8	11	18	22	31,5	48,5	11	18	23	30	58	39	61			
9						12	18	23	30	56	38	60			
10						13	19	24	30	55	38	59			
11											38	58			
12											41	60			
Nennhubarbeit W_N (Ncm)	9,0	14,7	17,6	25,2	38,8	12,8	18,7	23,7	30,1	55,1	49,0	72,3	on request		
Rated power P_{20} (W)	19,1	44,3	61,5	104,7	213,0	18,6	41,2	56,7	91,7	239,0	36,0	77,3			
Actuation time t_1 (ms)	135	100	90	80	70	170	130	110	100	85	265	185			
Fall time t_2 (ms)	40	40	35	30	30	55	50	45	40	30	60	60			
Inductance * (mH)															
* Armature in stroke start position s_{max}	467	on request				736	on request				696	on request			
* Armature in stroke end position s_0	280	on request				371	on request				427	on request			
Armature weight $m_{armature}$ (kg)	0,05					0,06					0,20				
Solenoid weight m_M (kg)	0,4					0,6					1,5				

* measured via switch-off energy (according to V1350.5786)

Table 1

Notes on the tables

The force values indicated in the tables refer to 90 % of the rated voltage, ($U_N = 24$ V, for other voltages deviations of magnetic force may occur) and in the normal operating temperature.

Due to natural dispersion the force values and the force values of the spring may deviate by ± 10 % from the values indicated in the tables.

The normal operating temperature is based on:

- Mounting on badly conductive base
- Rated voltage $U_N = 24$ V
- Operating mode S1 (100%)
- Reference temperature 35° C

Rated voltage

Rated voltage is $U_N = 24$ V. An adaptation of the exciter coil to a rated voltage less than $U_N = 120$ V is possible on request.

Standard values for voltage and operating mode: 24V, S1 (100%).

The devices correspond to protection class III. Electrical equipment of protection class III may be only connected to low voltage systems (PELV, SELV)(IEC 60364-4-41). The design limit of the equipment is a rated voltage not higher than 120 V (EN 61140:2002) with DC. On request we are pleased to check to what extent the delivery of higher rated voltages is possible as special solutions by agreement.

Solenoid body

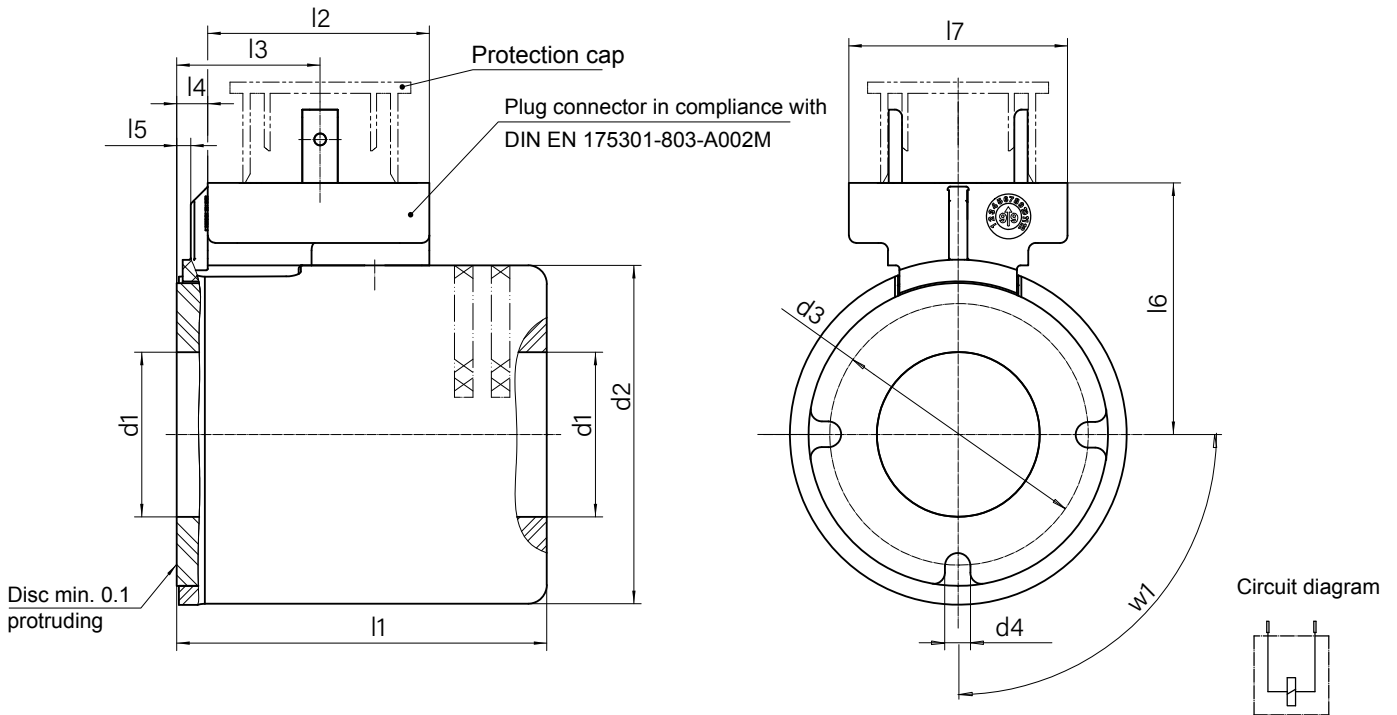

Size	037	045	063
Material no.	927135	927137	927138
Dimensions in mm / electrical data see table 1			
d1	Ø 19	Ø 22	Ø 31
d2	Ø 37	Ø 45 ±0.3	Ø 63
d3	-	-	Ø 50.9 ±0.2
d4	-	-	Ø 3.45 ±0.1
l1	50	50.1 ±0.4	72 +0.6/-0.1
l2	30	30 ±0.5	31
l3	18.35	19.4 ±1	22
l4	3.15 ±0.4	4.2	5.8
l5	0.85 ±0.4	1.9 +0.4/-0.3	-
l6	29.7	33.7 ±1	42.2
l7	29.6	29.6 ±0.5	29.6
w1	-	-	90° ±30'

Table 2

Tube

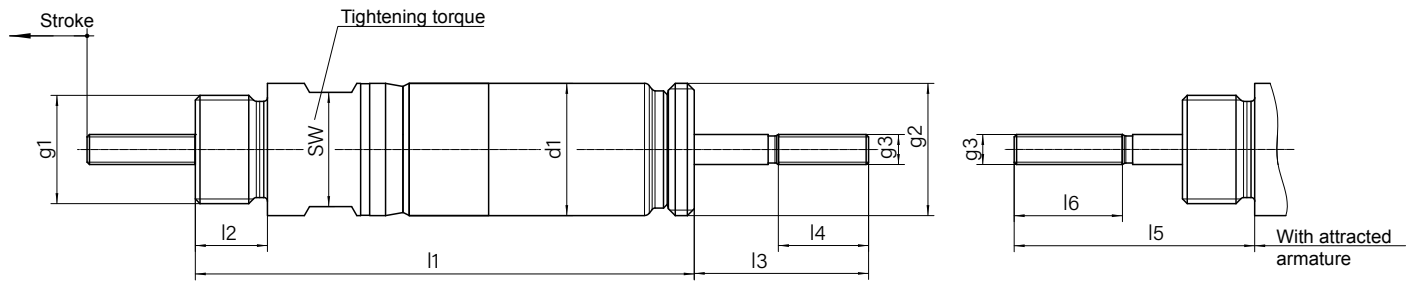

Size	037	045	063
Material no.	927732	927764	927177
	Dimensions in mm		
d1	Ø 19	Ø 22	Ø 31
l1	80.1	83	113
l2	12	12	12
l3	22.9	29	32.5
l4	15	15	18
l5	37 ±0.1	40 ±0.1	45 ±0.15
l6	15	18	21
Stroke	8	10	12
SW	SW17	SW19	SW27
Tightening torque (Nm)	13 bis 15	22 bis 24	46 bis 48
g1	M14x1.5	M18x1.5	M27x1.5
g2	M18x1.5	M22x1.5	M30x1.5
g3	M4	M5	M6

Table 3

Fastening nut

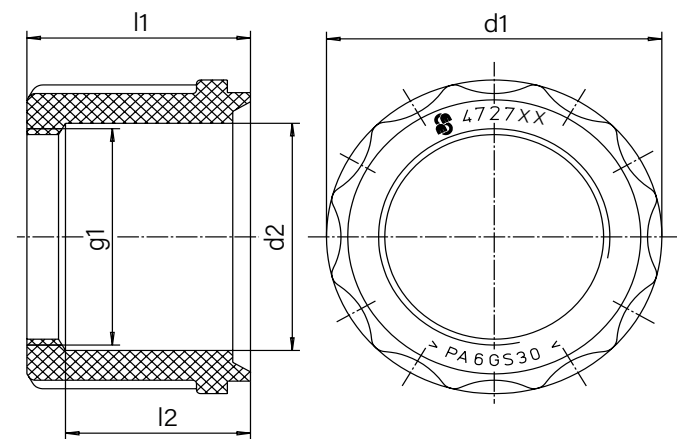

Size	037	045	063
Material no.	472793	472778	472794
	Dimensions in mm		
d1	Ø 30 ±0.3	Ø 35	Ø 43.5
d2	Ø 19.5 ±0.2	Ø 23.3 ±0.1	Ø 31.5
l1	20	21	29
l2	15	15	24
g1	M18x1.5	M22x1.5	M30x1.5

Table 4

Single-acting solenoid complete

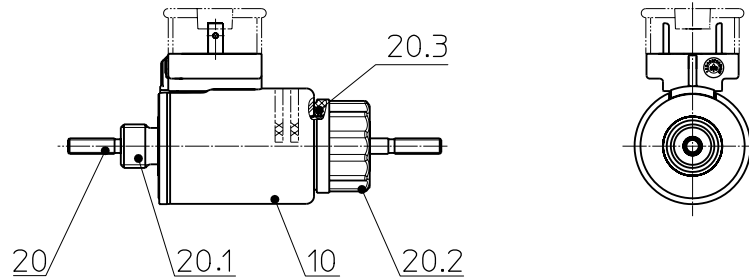

Size	Pos.	Designation	Material no.	Designation 2	Remark
037	10	Solenoid body FHM037	927135 005	24VDC, 100% ED Montage auf Ventilkörper	Order description for complete unit please order pos. 10 + 20
	20	Tube complete FMTX037	902361	bagged	
	20.1	Tube FMTX037	927732		Supplied as tube compl. (included in Pos. 20)
	20.2	Fastening nut	472793	Suitable socket wrench SW26 (12 kt DIN 3124) Tightening torque 5+1 Nm	
	20.3	O-ring	781754	19x2,5 70 Sh-A NBR	
045	10	Solenoid body FHM045	927137 002	24VDC, T4, 100% ED Montage auf Ventilkörper	Order description for complete unit please order pos. 10 + 20
	20	Tube complete FMTX045	902362	bagged	
	20.1	Tube FMTX045	927764		Supplied as tube compl. (included in Pos. 20)
	20.2	Fastening nut	472778	Suitable socket wrench SW30 (12 kt DIN 3124) Tightening torque 6 ⁺¹ Nm	
	20.3	O-ring	781744	22x2,5 70 Sh-A NBR	
063	10	Solenoid body FHM063	927138 004	24VDC, T4, 100% ED Montage auf Ventilkörper	Order description for complete unit please order pos. 10 + 20
	20	Tube complete FMTX063	902360	bagged	
	20.1	Tube FMTX063	927177		Supplied as tube compl. (included in Pos. 20)
	20.2	Fastening nut	472794	Suitable socket wrench SW38 (12 kt DIN 3124) Tightening torque 6 ⁺¹ Nm	
	20.3	O-ring	781755	31x2,5 70 Sh-A NBR	

Table 5

Information and remarks concerning European directives can be taken from the correspondent information sheet which is available under *Produktinfo.Magnet-Schultz.com*.

Please make sure that the described devices are suitable for your application. Our offers for these devices are based on the assumption of maximal 8 in an FMEA severity table, i. e. in case of malfunction of the device model as offered, there is, amongst others, no jeopardy of life or limb. Supplementary information concerning its proper installation can be taken also from the  –Technical Explanation, the effective DIN VDE0580 as well as the relevant specifications.

This part list is a document for technically qualified personnel. The present publication is for informational purposes only and shall not be construed as mandatory illustration of the products unless otherwise confirmed expressively.

Order example

Please note that for a functional unit always a combination of solenoid body and tube must be ordered.

Solenoid body	Designation:	Solenoid body F HM G 037
	Material no.:	927135 005
	Rated voltage:	24 V DC
	Duty cycle:	100% ED

Tube	Designation:	Tube F MT X 037
	Material no.:	902361

Specials designs

Please do not hesitate to ask for our assistance with the solution of your application-oriented task. In order to find rapidly a reliable solution we need complete details about your application conditions. The details should be specified as precisely as possible in accordance with the relevant  -Technical Explanations.

If necessary, please request the support of our corresponding technical office.