

## Electric Bolt Lock

## Type TALL-1515

Benefit from more than 100 years of experience. Use our unmatched end-to-end service: from off-the-shelf products to tailor-made designs - prototyped, tested and manufactured to your exact requirements.

Get free advice, a detailed quote or buy now

Email us at [sales@magnetschultz.co.uk](mailto:sales@magnetschultz.co.uk) or call +44(0)1483 794700

Robust and secure for passenger lift applications

### Function

- spring-to-lock (SL)
- 2 bolt position switches (extended)
- integral manual over-ride
- 15mm bolt stroke

### Standard features

- 15mm diameter bolt
- standard Amphenol C091 connector
- designed to Lifts Directive
- robust construction
- maintenance-free bearings, long life operation
- corrosion resistant materials
- 24 Vdc

### Options on request

- different bolt lengths

### Standards and Directives

- ISO 9001
- solenoid designed and tested to VDE 0580
- Lifts Directive 2014/33/EU (pending approval)

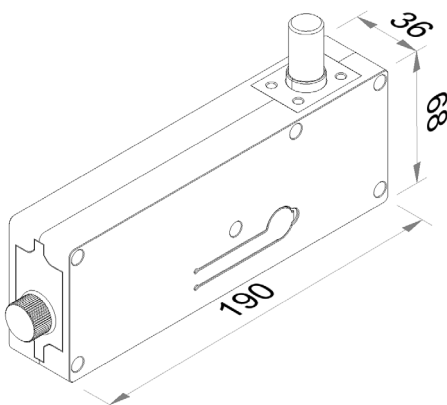

Fig. 1 TALL-1515